

High Lifter Products, Inc.
780 Professional N. Dr.
Shreveport, LA 71105



(318) 524-2270
Fax (318) 524-2297

Honda 500 Lift Kit **Installation Instructions**

Read Before Installation!

This product is designed for use on ATVs on which additional ground clearance and fender clearance is desired. It is designed for utility type, slower-speed use on relatively flat terrain in deep mud or snow. Although we have many thousands of satisfied lift kit customers and over 400 franchised dealers selling and installing lift kits, purchasers should be aware that use of this product may increase the frequency of required maintenance, part wear, and will raise the center of gravity on your ATV increasing risk of roll-over on side hills, ditches or other steep terrain.

We recommend that wider tires and/or wheel spacers be used to achieve a wider stance and to improve stability of the ATV. Riders should be advised that the handling characteristics of a taller ATV are different and require extra care when riding on side hills or off-camber situations. If you further raise the center of gravity by adding heavy loads to racks or seats, the ATV must be operated with care, at slower speeds or on relatively flat ground.

Operation of an ATV with or without a lift kit, while or shortly after consuming alcohol or drugs, subjects the rider to the risk of serious bodily harm or possible death. This is compounded if the rider does not wear an approved helmet and other safety gear. High Lifter urges that all approved safety gear be worn when riding an ATV.

If this is not what you expected, or is not consistent with your intended use, you should return the product immediately to the seller, **before installation**, for a refund of the purchase price; less any fees. After installation, product is warranted for 90 days for defects in workmanship and materials. Warranty is limited to refund of the purchase price or replacement of the kit, at the seller's option.

This lift kit contains the following parts:

10x55mm Bolts	4
10x45mm Bolts	2
10mm Nuts	6
1" x 1 3/4" Hex Head Bolt	4
1/4" Nuts	4
Lift Brackets & Spacers	16
Pages of Instructions	7

Parts List

A - Qty 2

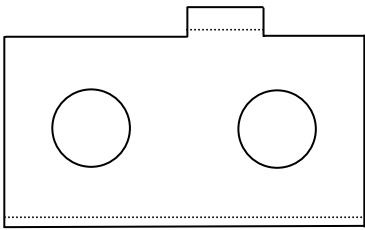

B - QTY 2



C - Qty 2

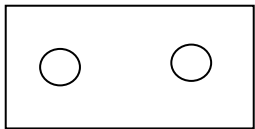

D - Qty 2



E - Qty 2

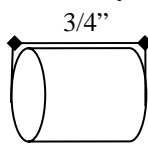

F - Qty 2

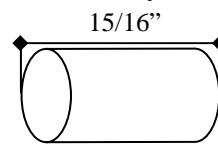

G - Qty 1

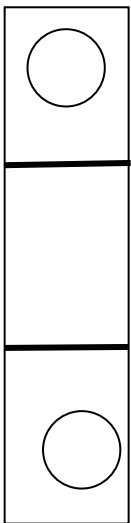

H - Qty 1

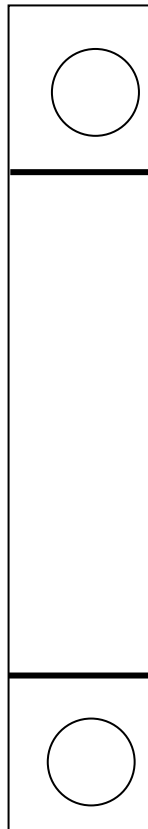

I - Qty 2

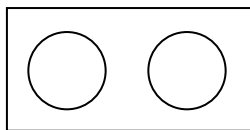

J - Qty 2



10 x 55mm Bolt - Qty 4



1" x 1 3/4" Hex Head - Qty 4



10 x 45mm Bolt - Qty 2



10mm Lock Nut - Qty 6

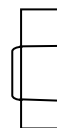

1/4" Lock Nut - Qty 4



Front Lift

- 1) Place jack under center of ATV front end and lift until front wheels clear the ground. Be careful to support ATV properly so that it's secure, but so that the A-arms and shocks can droop to full extension.
- 2) Remove front wheels and shock.
- 3) Place spacer "F" on the inside of the shock mount, place bracket "A", with the notch down and inward over the shock mount. Secure this bracket with a **10x55mm bolt** that is provided with the kit.

Note: The following 2 steps should be read and done at the same time, before action is taken.

Hint: Place 10x55mm bolt through bracket "B" before using the bolt to secure the bottom of the shock eyelet.

- 4) Place bottom of shock inside top of bracket "A", placing spacer "D" between the rear of the shock eyelet and the inside of bracket "A", securing it with a new **10x55mm bolt** from front to back.
- 5) Next, place bracket "B" on bracket "A" (on the front outside of bracket "A") securing it with a new **10mm Nut**.
- 6) Install Bracket "B" on the front of the A-arm and Bracket "C" on the rear of the A-arm, then secure with two $\frac{1}{4}$ " x $1\frac{3}{4}$ " **Hex Head Bolts**. Place a $\frac{1}{4}$ " **Lock Nut** on the U-Bolt. Before tightening all nuts ensure the angle of the shock is at the same original angle.
- 7) Tighten all bolts to manufacturer specifications.
- 8) Repeat this procedure for the other side.
- 9) Install the wheels, torque wheel lugs to manufacturer's specifications, lower and remove jack. Check for clearance problems or misalignment.

Front Installation Diagram

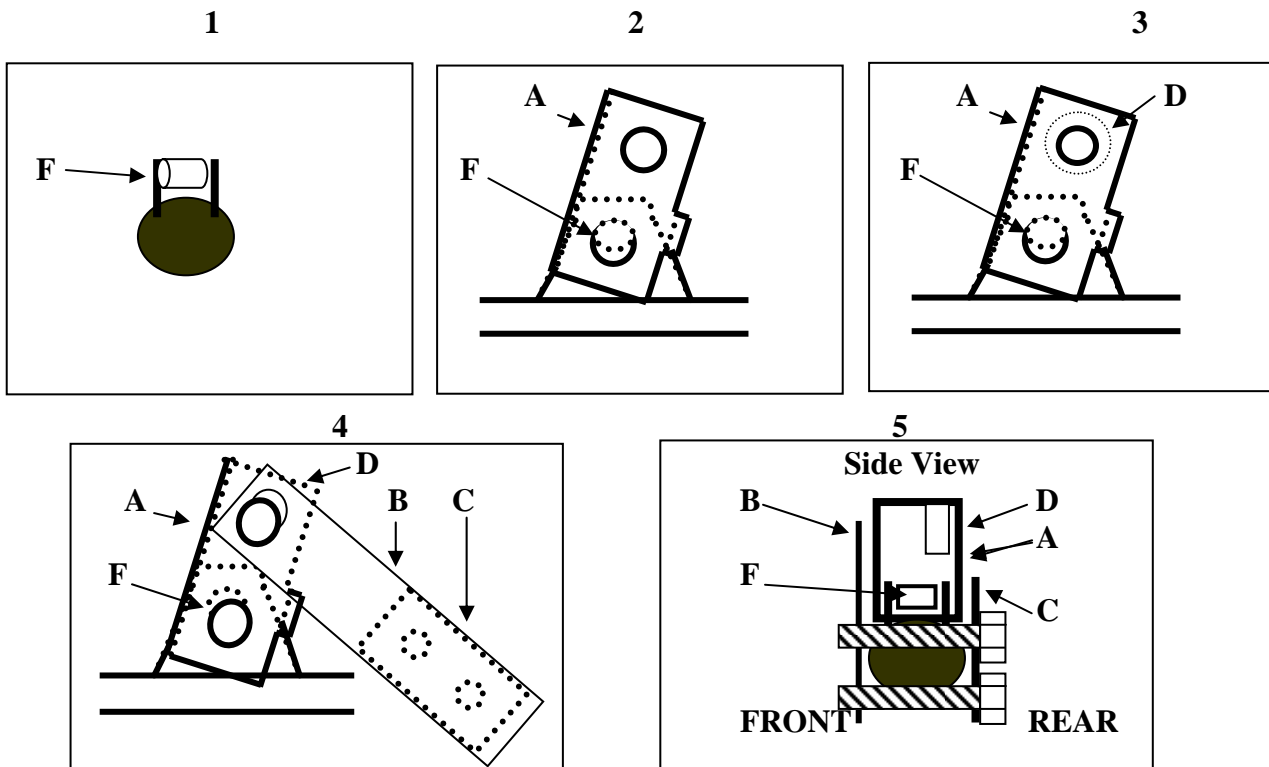

Rear Lift

Left Side

- 1) Place jack under ATV at the rear of the bottom engine skid plate (**not the differential**), and lift until the weight is off of the suspension. Be careful to secure the ATV properly so as not to fall off the jack.
- 2) After removing the bottom of the shocks, jack the ATV up an additional 1"-2".
- 3) Remove the top bolt on the left side of the differential housing, closest to the shock mount.
- 4) Place bracket "J" on the left outside of the shock mount (notch up).
- 5) Place spacer "E" on the inside of the shock mount.
- 6) Place bracket "I" between spacer "E" and the inside of the shock mount, (to the right of spacer "E" and to the left of the inside wall of the shock mount).
- 7) Secure this with the stock OEM bolt.
- 8) Place the bottom of the shock (bottom shock eyelet) between brackets "J" and bracket "I", securing this with a **10x45mm Bolt**. Install bolt from left to right.
- 9) Place end of bracket "G" to the right and outside of bracket "I" securing it with a **10mm Nut**.
- 10) Last, secure the end of bracket "G" to the differential housing, use the OEM nut.
- 11) **DO NOT TIGHTEN NUTS AND BOLTS AT THIS TIME. TIGHTEN AFTER COMPLETION OF RIGHT SIDE.**

Left Rear Installation Diagram

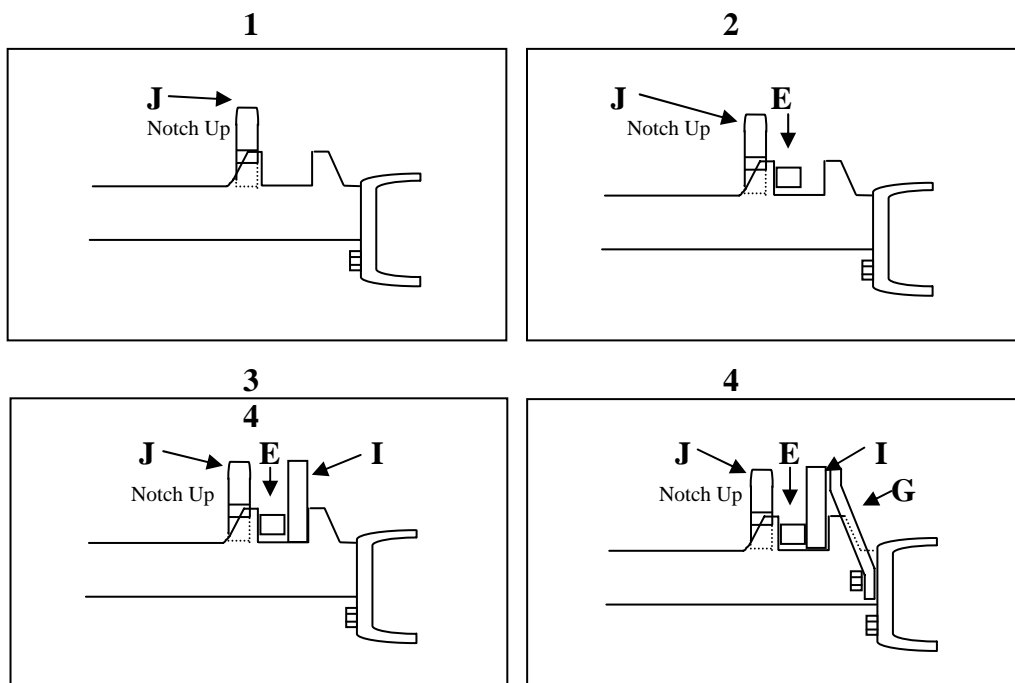

Right Side

- 1) Place bracket “J” on the right outside of the shock mount (notch up).
- 2) Place spacer “E” on the inside of the shock mount.
- 3) Place bracket “I” between spacer “E” and the inside of the shock mount, (to the left of spacer “E” and to the right of the inside wall of the shock mount).
- 4) Secure this with the stock OEM bolt.
- 5) Place bottom of shock (bottom shock eyelet) between brackets “J” and bracket “I”, securing this with a **10x45mm Bolt**. Install bolt from right to left.
- 6) Place end of bracket “H” to the differential housing using the OEM bolt.
- 7) **Tighten all bolts to manufacturer’s torque specifications, on BOTH THE LEFT AND RIGHT SHOCK MOUNT!**

Both Sides

- Tighten all bolts to manufacturer’s torque specifications.
- Lower and remove jack.
- Check for clearance problems or misalignment.

Right Rear Installation Diagram

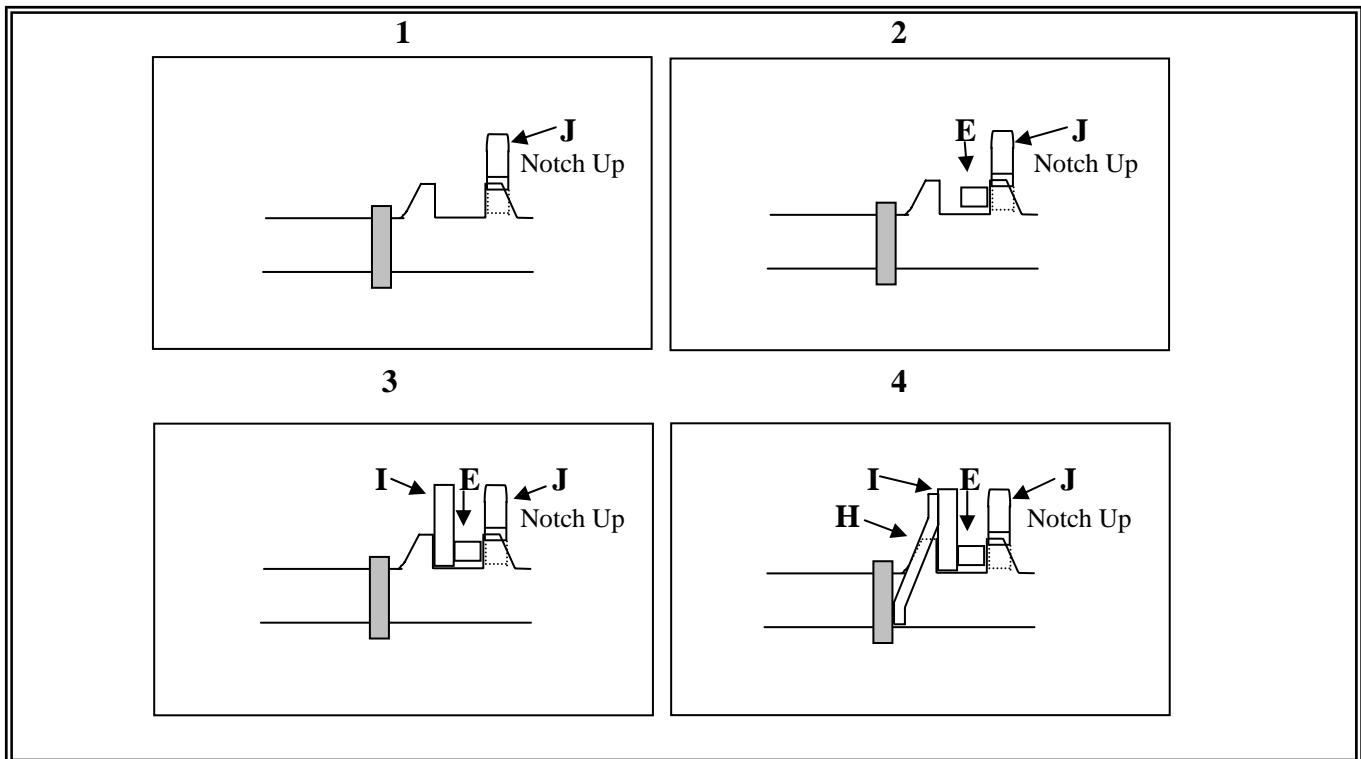

Front Installation Picture

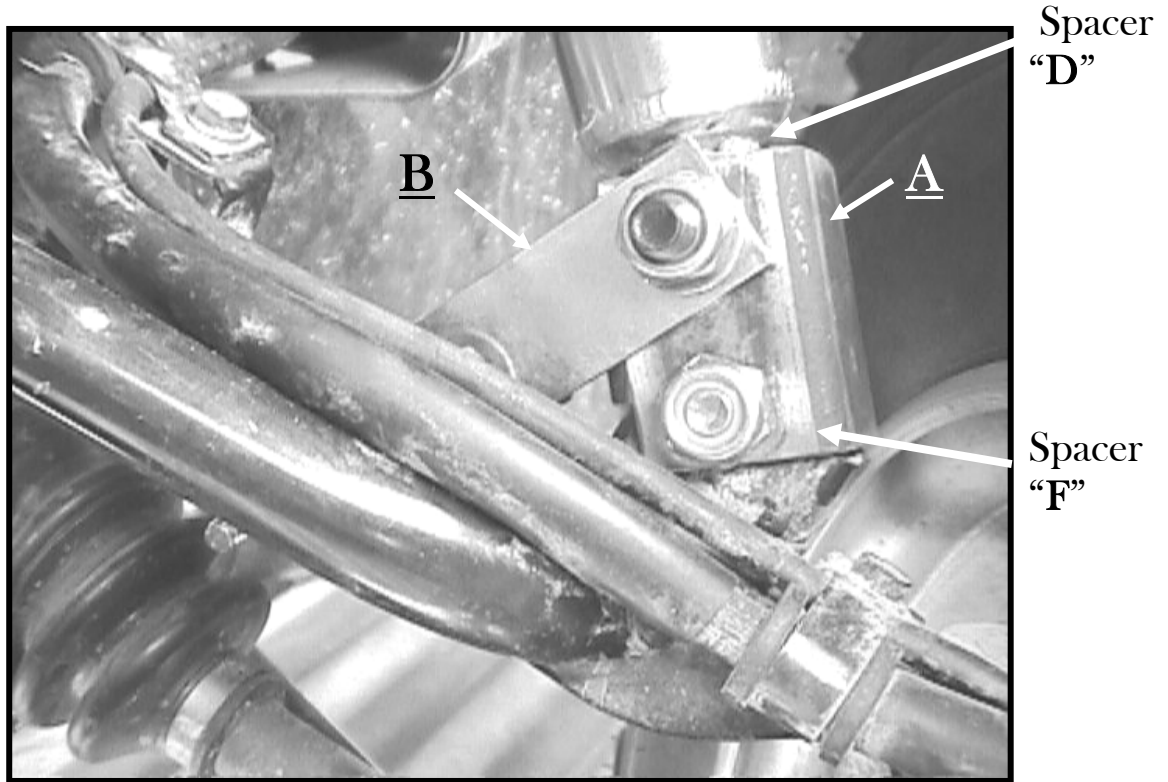

Rear Right Installation Picture

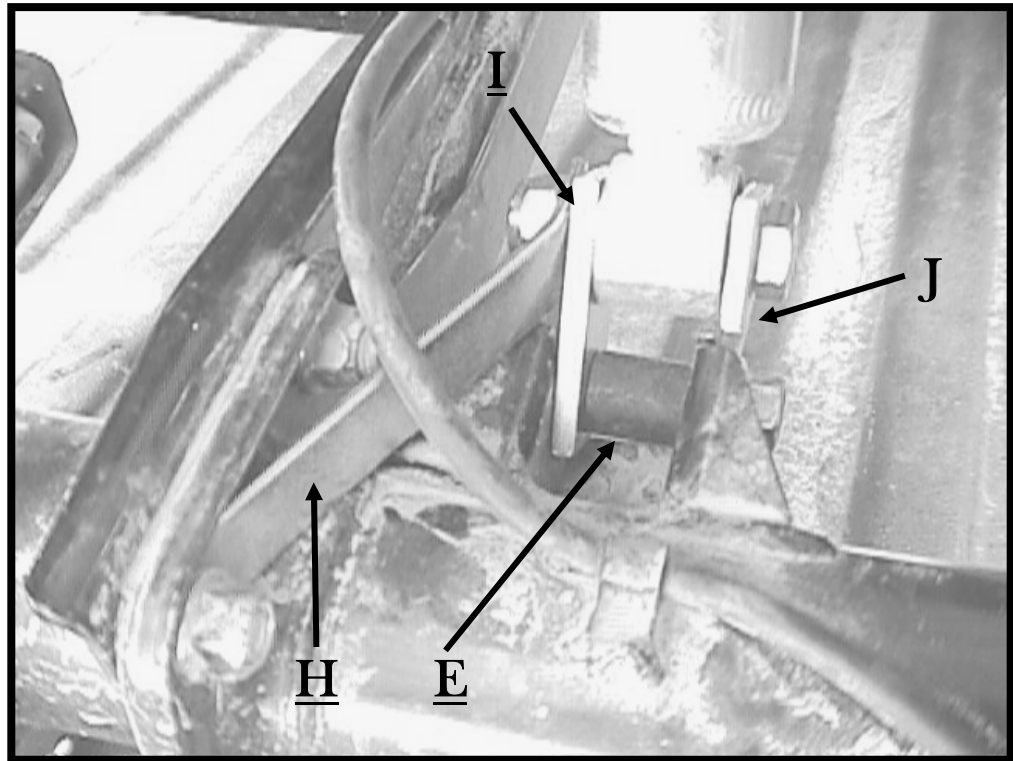

Rear Left Installation Picture

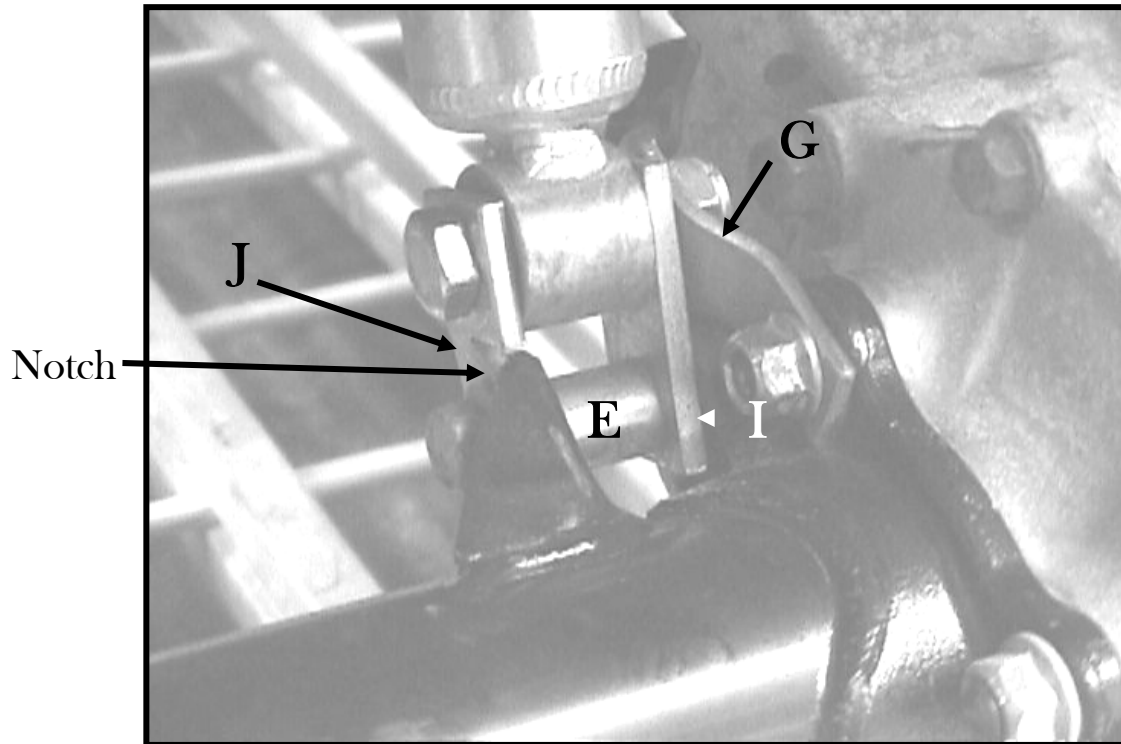

Check out our other products for the Rubicon:

Fender Kit: Run big monster tires on front of ATV with no rubbing!

28" Outlaw Mud Tires: Biggest, Baddest, Gnarliest mud tire in the World!

Front Bash Plate: (Diamond plate aluminum) replaces plastic nosepiece and protects radiator.

Full Bottom Skid Plate: (Mill plate aluminum) Has an Oil Filter Access Panel for easy access to change the oil.

Multi Seal Air Lock Tire Sealant: Plugs holes instantly up to $\frac{1}{2}$ " in tread, $\frac{1}{4}$ " in sidewall, and STOPS BEAD LEAKS!

K&N Power Kits: Give your Rubicon more power!